

SERVICE & MAINTENANCE PRODUCTS 2012 / 2013



With Rexnord products around service and maintenance of our forklift technology, we ensure our productivity, and increase profitability.

Reduce maintenance costs.
Increase earnings.

With **RexDura** leaf chains.

Chain lifetime:

Chain inspection every:

RexPro

8000h

500h

RexDura

16000h

2500h

Example. For further informations contact our engineering center.

CHAIN **INNOVATIONS** BY

REXNORD



Rexnord Kette GmbH

Postfach 120
57501 Betzdorf / Germany

Fon +49 2741 284-0
Fax +49 2741 284-274

E-Mail: rexinfo@rexnord.com
www.rexnord-kette.de



More about the new RexDura on youtube:
<http://www.youtube.com/watch?v=8wHqRFfgwUQ>

REXNORD QUALITY CHAINS - WORLDWIDE

Rexnord has been manufacturing chains in many different designs since 1892. The experience gained in many decades as well as consistent research ensures chain products of an advanced design and a high degree of dependability. Rexnord manufactures at 4 locations on 4 continents. A large number of patents confirm the extraordinary innovative spirit which bears witness to this company. Wherever applications of extreme quality are required, Rexnord products are there, meeting the highest of demands. Currently 8 of the 10 biggest forklift chain manufacturers are using Rexnord chains!

ADVANTAGES OF REXNORD CHAINS

Roller chains belong to products complying with the DIN Standard, but contrary to widespread opinion, the quality of a chain is not governed by breaking load, but by the ability to survive repeated operating loads and wear life.

True quality is measured in terms of fatigue strength and resistance to wear. This means that in reality, roller chains from different manufacturers with the same tensile strength are not always the same in their quality, despite standardization. The production methods developed and practiced by Rexnord enable an optimum combination of quality-determining factors such as fatigue strength and resistance to wear.

Rexnord Kette GmbH maintain a quality man-

agement system which is reflected in the special commitments to their customers.

The quality management handbook describes the quality management system of Rexnord Kette GmbH.

Thereby all Rexnord customers have access to the information how Rexnord realizes and guarantees their products.

Similarly, all Rexnord employees are provided with guidelines, which help to support and motivate them in their endeavours to work with quality-consciousness.

This handbook contains an all-round binding description, which is according to the internationally known DIN EN ISO 9001 and DIN EN ISO 14001. Furthermore, process details, working details and testing methods as well as all-round processing practices are available to the employees.

The products from Rexnord and its organisation undergo systematic optimization processes. Consequently, external and internal feedback is followed with eager interest and market-orientated demands observed with a watchful eye, both contributing and correctively improving production processes.



Safety hoisting chains

Leaf Chains are often a safety-critical component part. For this reason Rexnord Leaf Chains are supplied marked with a batch number. This allows traceability to process and inspection-records right back to the raw material and its supplier.

Rexnord leaf chains additionally provide:

- Outstanding corrosion protection!
- protection against stiff chain links
- Improved wear protection!
- longer working life
- No heavy metals!
- H2 Approval-conforms to RoHS conformity



Leaf chains, odd lacings

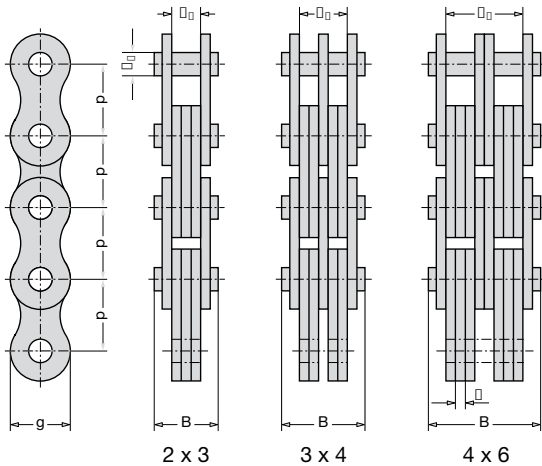

Leaf chains, even lacings

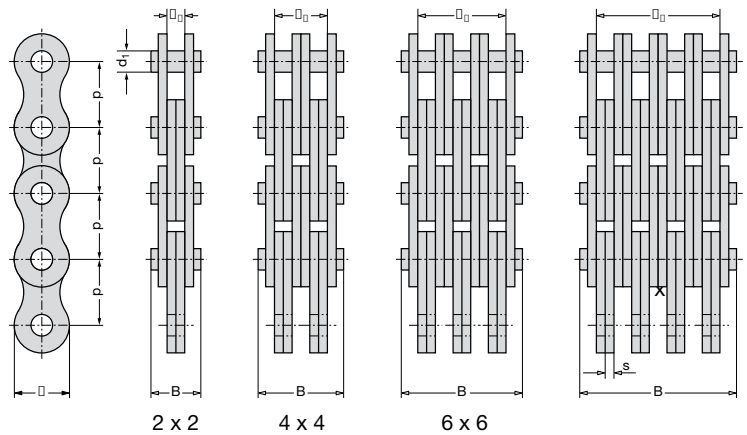

BL-Series Leaf chains acc. to ISO 4347 / DIN 8152, American standard, Heavy series

Chain No.	Chain description	Pitch p		Plate combinations	Pin Ø	Link plate height	Link plate thick	Length over 100 x Pitch	Total weight	Bearing area	Link plate width	Min. ultimate strength required *) acc. to DIN/ISO	Weight
		inch	mm										
BL 422	LH 0822	0,5	12,7	2 x 2	5,08	11,7	2	1270	10,9	0,2	4,2	22 200	0,6
BL 423	LH 0823			2 x 3					13	0,3	6,3	22 200	0,65
BL 434	LH 0834			3 x 4					17,1	0,41	10,5	33 300	0,9
BL 444	LH 0844			4 x 4					19,25	0,41	12,6	44 400	1,02
BL 446	LH 0846			4 x 6					23,45	0,61	16,8	44 400	1,26
BL 466	LH 0866			6 x 6					27,6	0,61	21	66 600	1,51
BL 523	LH 1023	0,625	15,875	2 x 3	5,94	14,6	2,4	1596	15	0,43	7,4	33 400	1,1
BL 534	LH 1034			3 x 4					20	0,57	12,3	50 100	1,5
BL 544	LH 1044			4 x 4					22,5	0,57	14,7	66 800	1,8
BL 546	LH 1046			4 x 6					27,3	0,86	19,5	66 800	23,2
BL 566	LH 1066			6 x 6					32,3	0,86	24,6	100 200	2,6
BL 588	LH 1088												
BL 622	LH 1222	0,75	19,05	2 x 2	7,92	17,8	3,2	1908	16,6	0,51	6,4	48 900	1,5
BL 623	LH 1223			2 x 3					19,9	0,74	9,6	48 800	1,8
BL 634	LH 1234			3 x 4					26,5	0,98	16	73 400	2,5
BL 644	LH 1244			4 x 4					29,7	0,98	19,2	97 800	2,9
BL 646	LH 1246			4 x 6					36,3	1,47	25,6	97 800	3,6
BL 666	LH 1266			6 x 6					42,7	1,47	32	146 900	4,3
BL 822	LH 1622	1	25,4	2 x 2	9,53	23,6	3,9	2544	20,6	0,74	8,2	84 500	2,4
BL 823	LH 1623			2 x 3					24,8	1,14	12,3	84 500	3
BL 834	LH 1634			3 x 4					33,1	1,52	20,5	126 800	4,2
BL 844	LH 1644			4 x 4					37,3	1,52	24,6	169 000	4,8
BL 846	LH 1646			4 x 6					45,7	2,29	32,8	169 000	6
BL 866													
BL 888													
BL 1023	LH 2023	1,25	31,75	2 x 3	11,1	29,2	4,7	3179	28,9	1,56	14,4	115 600	4,4
BL 1034	LH 2034			3 x 4					38,7	2,09	24	173 400	6,2
BL 1044	LH 2044			4 x 4					43,7	2,09	28,8	231 200	7
BL 1046	LH 2046			4 x 6					53,5	3,12	38,4	231 200	8,7
BL 1066	LH 2066			6 x 6					63,4	3,12	48	346 800	10,5
BL 1088	LH 2088			8 x 8					83	4,17	67,2	462 400	13,9
BL 1223	LH 2423	1,5	38,17	2 x 3	12,7	34,4	5,5	3812	33,6	2,1	16,8	151 200	6
BL 1234	LH 2434			3 x 4					45,5	2,79	28	226 800	8,3
BL 1244	LH 2444			3 x 4					51,2	2,79	33,6	302 400	9,5
BL 1246	LH 2446			4 x 6					62,7	4,2	44,8	302 400	11,8
BL 1266	LH 2466			6 x 6					74,5	4,2	56	453 600	14,1
BL 1288	LH 2488			8 x 8					97,8	5,4	78,4	604 800	18,8
BL 1423	LH 2823	1,75	44,45	2 x 3	14,27	40,8	6,3	4445	38,2	2,7	19,2	191 300	8,3
BL 1434	LH 2834			3 x 4					51,7	3,6	32	287 000	11,6
BL 1444	LH 2844			4 x 4					58,2	3,6	38,4	382 600	13,2
BL 1446	LH 2846			4 x 6					71,5	5,4	51,2	382 600	16,4
BL 1466	LH 2866			6 x 6					85	5,4	64	574 000	19,7
BL 1488	LH 2888			8 x 8					111,7	7,2	89,6	765 200	25,9
BL 1623	LH 3223	2	50,8	2 x 3	17,46	47,9	7	5080	42,1	3,67	21,3	289 100	11
BL 1634	LH 3234			3 x 4					57	4,89	35,5	433 700	15,4
BL 1644	LH 3244			4 x 4					63,8	5	42,6	578 200	17,5
BL 1646	LH 3246			4 x 6					78,9	7,33	56,8	578 200	21,8
BL 1666	LH 3266			6 x 6					95	7,33	71	867 400	26,2
BL 1688	LH 3288			8 x 8							97,8	99,4	1 156 400

BL leaf chains can be directly fastened by using connecting pins. They do not need additional end plates.

Wherever possible, it is best to select BL- leaf chains.
Further plate combinations upon request.
Please note the following the specs.:
Length over 100 x Pitch

■ chain length: Tolerance $\pm 0.25\%$ of uncoiled chain under measured load. Measured force = $\frac{F_B}{100}$

F = pin and plate dimensions correspond to roller chain series acc. to DIN 8187.

AL = pin and plate dimensions correspond to ANSI standard.

BL = pin and plate dimensions correspond to ANSI standard, however these leaf chains possess the plate thickness and pin Ø of the next largest corresponding chain size, to achieve a larger bearing area and tensile strength, and consequently longer working life for the BL leaf chains.

*) Details about the effective higher Rexnord ultimate strengths and fatigue strength values are available upon request.

F Series: Machine tool quality

Use machine tool chains from the „F“ series in special machine tool quality! The effective pitch dimensions for leaf chains from the series F and AL vary somewhat from the theoretical values.

Please note the following specs.: „Length over 100 x Pitch“.

K Chain length: Tolerance $\pm 0,25\%$ of uncoiled chain under measured load.

$$\text{Measured force} = \frac{F_B}{100}$$



Leaf chains, lacings

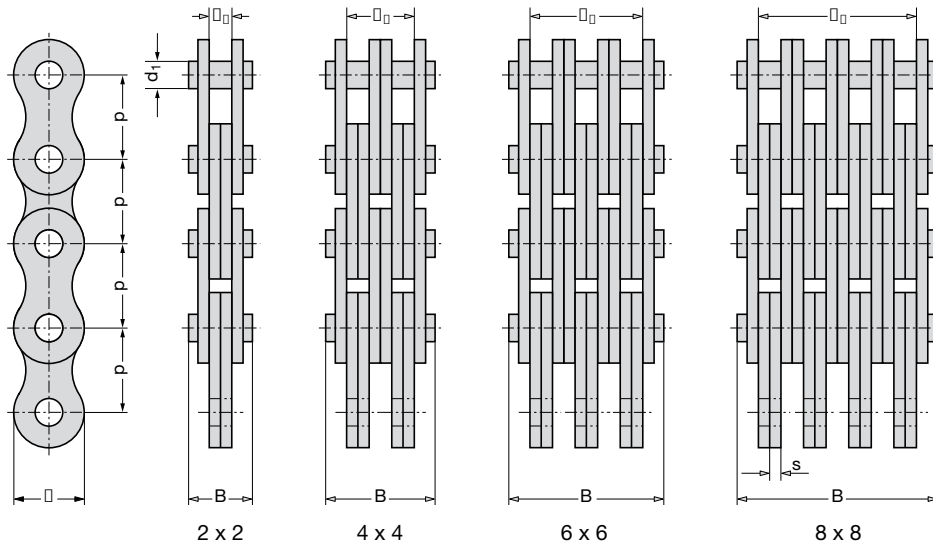

Leaf chains, Industry standard

Chain No.	Chain description	Pitch p		Plate combinations	Pin Ø	Link plate height	Link plate thick	Length over 100 x Pitch	Total weight	Bearing area	Min. ultimate strength required *) acc. to DIN/ISO	Weight
		inch	mm									
F 6 H – 5	–	0,625	15,875	2 x 3	4,75	14,6	2,5	1592	14,9	0,24	30 300	1
F 19 V – 44	–	0,75	19,05	4 x 4	6,5	15,2	2,35	1901	22,4	0,61	71 000	1,75 P
F 19 V – 66	–	0,75	19,05	6 x 6	6,5	15,2	2,35	1901	32,7	0,91	106 000	2,5
834 (SK 507)	–	1	25,4	3 x 4	10,85	23,4	IL /AL	2544	28,4	1,37	125 000	3,6
432 (SK 508)	–			6 x 6			3,05/4,0		44,4	2,06	250 000	5,9

*) Details about the effective higher Rexnord ultimate strengths and fatigue strength values are available upon request.

Leaf chains, American standard, Light series

F-Series Leaf chains acc. to ISO 4347 / DIN 8152, European standard, Light series

Chain No.	Chain description	Pitch p		Plate combinations	Pin Ø	Link plate height	Link plate thick	Length over 100 x Pitch	Total weight	Bearing area	Link plate width	Min. ultimate strength required *) acc. to DIN/ISO	Weight
		inch	mm										
F 12 - 44	LL 0844	0,50	12,7	4 x 4	4,45	10,4	1,5	1270	15,0	0,27	9,1	36 000	0,83
F 12 - 66	LL 0866			6 x 6									
F 15 - 44	LL 1044	0,625	15,875	4 x 4	5,08	12,8	1,5	1596	15,2	0,30	9,6	44 800	0,92
F 15 - 66	LL 1066			6 x 6									
F 19 - 44	LL 1244	0,75	19,05	4 x 4	5,72	15,9	1,8	1890	18,0	0,41	11,4	59 000	1,4
F 19 - 66	LL 1266			6 x 6									
F 25 - 44	LL 1644	1,00	25,4	4 x 4	8,28	20,5	3,0	2540	28,4	0,99	18,6	120 000	2,9
F 25 - 66	LL 1666			6 x 6									
F 25 - 88	LL 1688	1,25	31,75	8 x 8	10,19	25,7	3,5	3160	53,0	1,98	43,4	240 000	5,8
F 31 - 44	LL 2044			4 x 4									
F 31 - 66	LL 2066	1,50	38,1	6 x 6	14,63	33,0	5,0	3785	48,2	2,12	36,0	285 000	6,4
F 31 - 88	LL 2088			8 x 8									
F 38 - 44	LL 2444	1,75	44,45	4 x 4	15,9	36,0	6,0	4410	62,9	2,83	50,4	380 000	8,4
F 38 - 66	LL 2466			6 x 6									
F 38 - 88	LL 2488	2,00	50,8	8 x 8	17,81	41,2	6,3	5048	29,4	1,90	12,3	200 000	5,2
F 44 - 22	LL 2822			2 x 2									
F 44 - 44	LL 2844	2,50	63,5	4 x 4	22,89	48,0	8,0	6340	54,7	3,80	36,8	400 000	10,4
F 44 - 66	LL 2866			6 x 6									
F 44 - 88	LL 2888	3,00	76,2	8 x 8	29,24	62,0	10,0	7620	80,2	5,70	61,4	600 000	15,6
F 50 - 22	LL 3222			2 x 2									
F 50 - 44	LL 3244	1,50	38,1	4 x 4	11,1	29,4	4,7	3810	32,5	2,24	12,9	250 000	6,5
F 50 - 66	LL 3266			6 x 6									
F 50 - 88	LL 3288	1,75	44,45	8 x 8	12,7	36,0	5,5	4445	112,0	8,94	92,0	1 000 000	25,3
F 63 - 22	LL 4022			2 x 2									
F 63 - 44	LL 4044	2,00	50,8	4 x 4	14,27	41,2	6,3	5080	73,1	7,30	49,4	710 000	17,7
F 63 - 66	LL 4066			6 x 6									
F 63 - 88	LL 4088	2,50	63,5	8 x 8	22,89	48,0	8,0	6340	139,9	14,60	116,0	1 420 000	35,1
F 76 - 22	LL 4822			2 x 2									
F 76 - 44	LL 4844	3,00	76,2	4 x 4	29,24	62,0	10,0	7620	49,7	5,83	20,3	560 000	15,4
F 76 - 66	LL 4866			6 x 6									
F 76 - 88	LL 4888	1,25	31,75	8 x 8	10,19	25,7	3,5	3160	172,8	23,30	144,0	2 240 000	59,8

AL-Series Leaf chains, American standard, Light series

Chain No.	Chain description	Pitch p		Plate combinations	Pin Ø	Link plate height	Link plate thick	Length over 100 x Pitch	Total weight	Bearing area	Link plate width	Min. ultimate strength required *) acc. to DIN/ISO	Weight
		inch	mm										
AL 422	-	0,50	12,7	2 x 2	3,96	10,2	1,5	1257	8,4	0,12	3,2	14 100	0,35
AL 444	-			4 x 4									
AL 466	-			6 x 6									
AL 522	-	0,625	15,875	2 x 2	5,08	12,8	2,0	1572	10,8	0,2	4,2	22 000	0,6
AL 544	-			4 x 4									
AL 566	-	0,75	19,05	6 x 6	5,94	14,8	2,4	1909	21,7	0,6	21,0	66 000	1,8
AL 622	-			2 x 2									
AL 644	-	1,00	25,4	4 x 4	7,92	20,5	3,1	2540	12,8	0,28	5,0	37 000	0,9
AL 666	-			6 x 6									
AL 688	-	1,25	31,75	8 x 8	9,53	25,7	4,0	3175	23,0	0,57	15,0	63 600	1,7
AL 822	-			2 x 2									
AL 844	-	1,50	38,1	4 x 4	11,1	29,4	4,7	3810	43,2	1,14	35,0	127 200	3,3
AL 866	-			6 x 6									
AL 1044	-	1,75	44,45	4 x 4	12,7	36,0	5,5	4445	37,3	1,52	24,6	177 000	4,9
AL 1066	-			6 x 6									
AL 1244	-	2,00	50,8	4 x 4	14,27	41,2	6,3	5080	54,0	2,29	41,0	265 500	7,3
AL 1266	-			6 x 6									
AL 1288	-	2,50	63,5	8 x 8	22,89	48,0	8,0	6340	43,7	2,08	28,8	254 000	6,4
AL 1444	-			6 x 6									
AL 1466	-	3,00	76,2	4 x 4	29,24	62,0	10,0	7620	63,4	3,12	48,0	381 000	9,5
AL 1666	-			6 x 6									

*) Details about the effective higher Rexnord ultimate strengths and fatigue strength values are available upon request.

Reduce maintenance costs.
Increase earnings.

With **RexDura** leaf chains.



RexDura - the new low maintenance leaf chain generation!

Properties:

- ▶ The service temperature range runs from -15° C to +55° C.
- ▶ For visual distinction, the outer plates of RexDura are silver-coloured.
- ▶ The RexDura version is available for all AL, BL and F series leaf chains according to ISO 4347 and factory standard chains on request.

Applications:

- ▶ Lift poles on industrial trucks
- ▶ Telescopic arms on aerial platforms and telehandlers
- ▶ Mobile and stationary lifting devices
- ▶ Use in machine tools

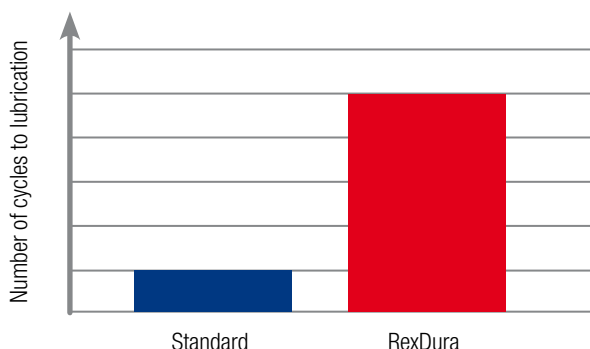

Advantages at a glance:

- ▶ Considerably extended re-lubrication intervals (extended by a factor of 5).
- ▶ The dimensions and mechanical properties such as breaking force and fatigue strength are identical to those of the standard version.
- ▶ Doubled wear lifespan.
- ▶ To ensure traceability, all Rexnord leaf chains are provided with a label number.
- ▶ Environmentally friendly. Reduced use of lubricants.
- ▶ Quiet-running. Reduces workplace noise.
- ▶ Compatible with all standard chains.

Over the entire range of tested link loads, the RexDura tribological system offers longer life cycles and much more protection against tribocorrosion (fretting-corrosion) and fatigue breakage due to wear. The wear lifespan is doubled compared to the standard chain.

Today many areas of drive technology require components which have extended maintenance intervals or are completely maintenance-free. The market launch of RexDura kicks off our range of maintenance-free components such as the high-performance leaf chains used in lift poles on industrial trucks and telescopic arms on aerial platforms and telehandlers.

When RexDura leaf chain is used, re-lubrication intervals can be extended by a factor of 5. That leads to much lower maintenance costs on the one hand and a considerably reduced environmental impact on the other. Conventional mineral oil based lubricants can be used for re-lubrication at a later



RexHiPro - Improved corrosion protection in difficult ambient conditions.

Objective:

- Anti-corrosion coating for all chain parts.
- No reduction of the mechanical properties like breaking load and fatigue strength
- All dimensions according to the DIN, ANSI and ISO standards
- No special sprocket is required.

Solution:

- Plates are coated with „RexHiPro“ (composition of zinc and aluminum flakes in an inorganic binder)
- HiPro coating is obtained by the application of an aqueous dispersion by cold immersion or spray and is therefore free of any risk of hydrogen embrittlement
- For the Leaf Chains the Pins and for the Roller Chains also the Rollers and Bushings are galvanic zinc-plated and passivated

Customers benefits:

- Leaf chains with high protection for applications in corrosive environments
- Higher efficiency than stainless steel, because of lower price and higher load capacity
- Same mechanical strength in breaking load, fatigue strength and load capacity
- Chain types that are already in service, can be treated with the HiPro surface. No change of existing design is necessary.

RexSpecial Chains

Special leaf chains with plastic protection parts are primarily used in forklift truck industry. Leaf chains with plastic center link plates are used to protect the chain and the hydraulic cylinder from damages by hitting each other during operation due to vibration and jamming. Leaf chains with plastic tube guiding elements provide highest safety for hydraulic tubes used in the forklift mast.

Rexnord special leaf chains additionally provide:

- Highest fatigue strength due to optimized press fit between pin and outer link
- Highest breaking load due to optimized plate strength
- Highest wear resistance due to high surface hardness of the pins



BL 623 KS

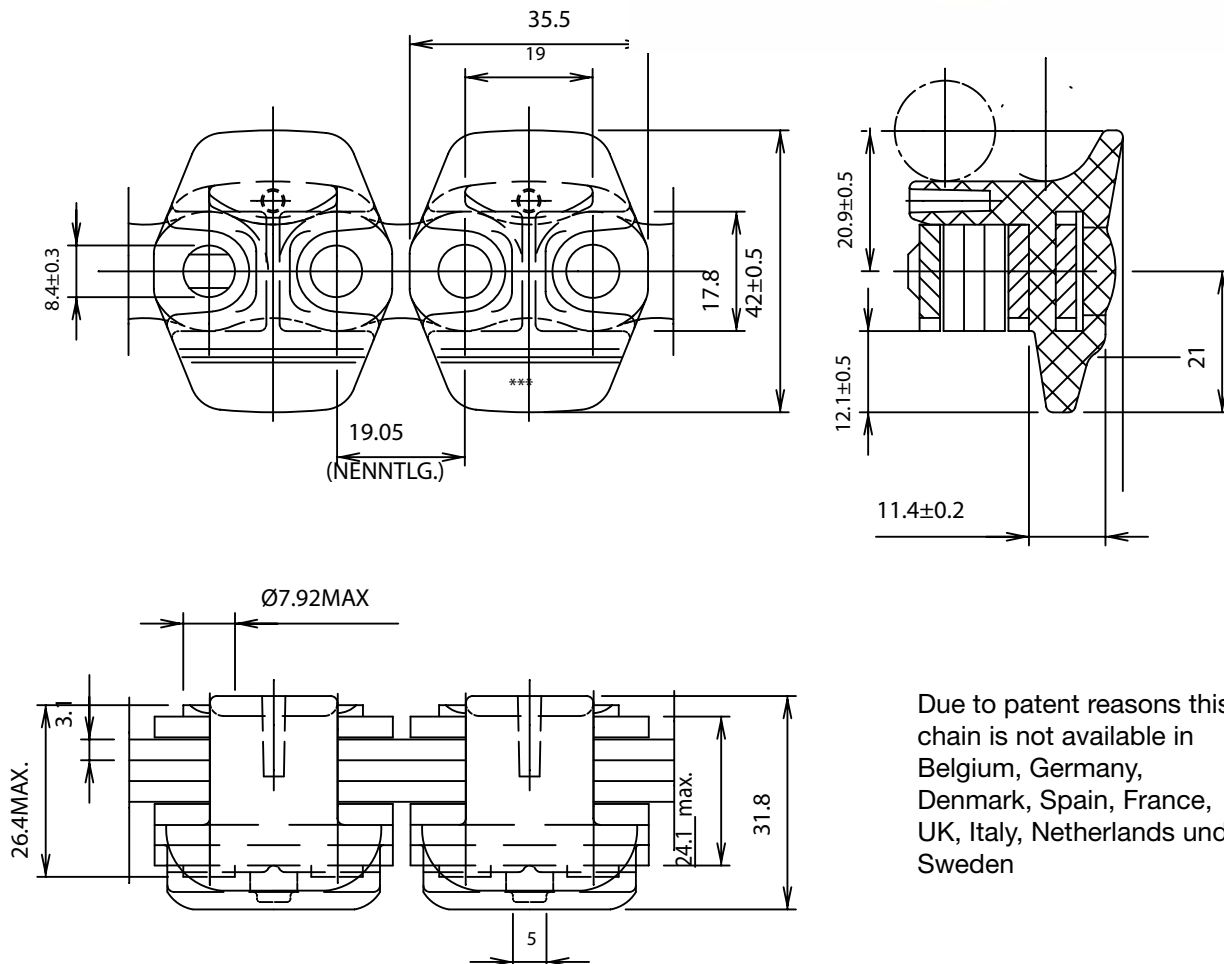

Due to patent reasons this chain is not available in Belgium, Germany, Denmark, Spain, France, UK, Italy, Netherlands und Sweden

BL 844 KS

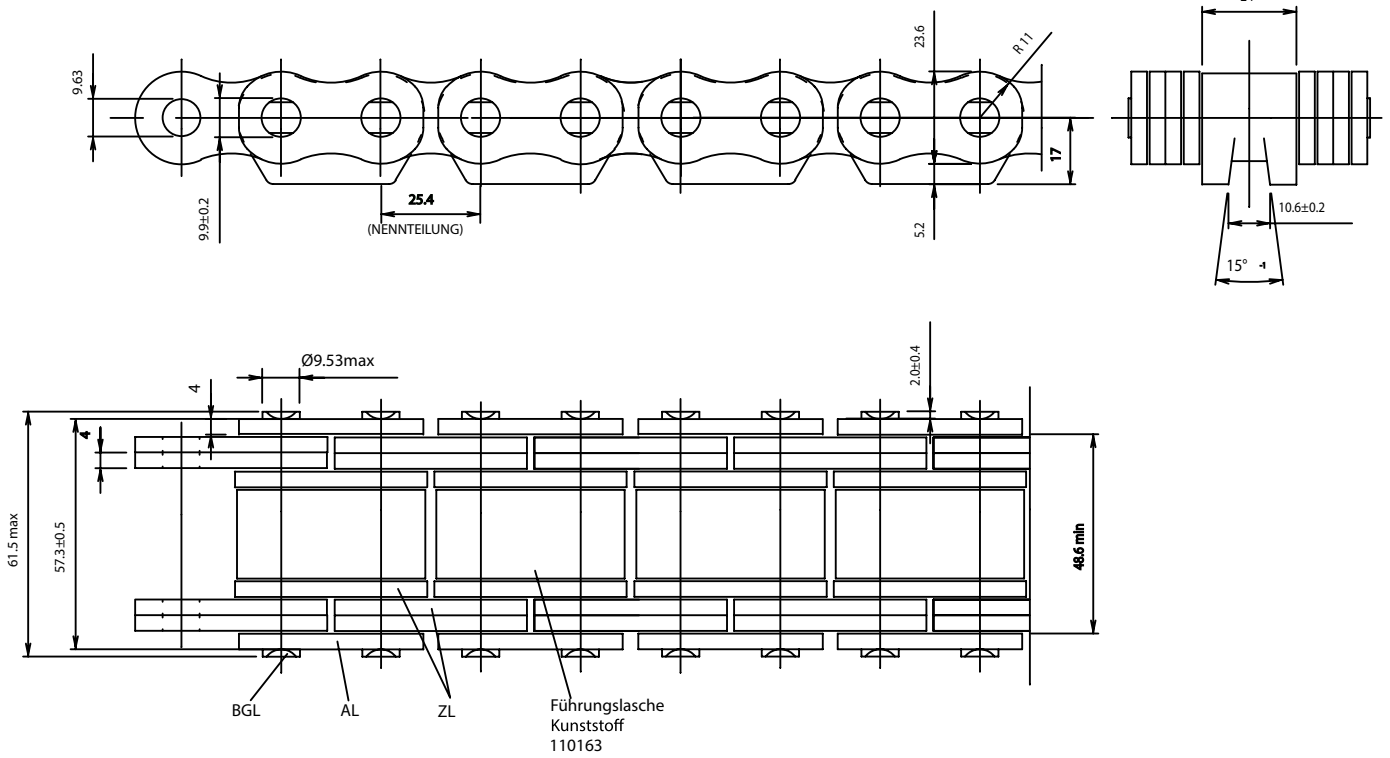

BL 866 BK KS

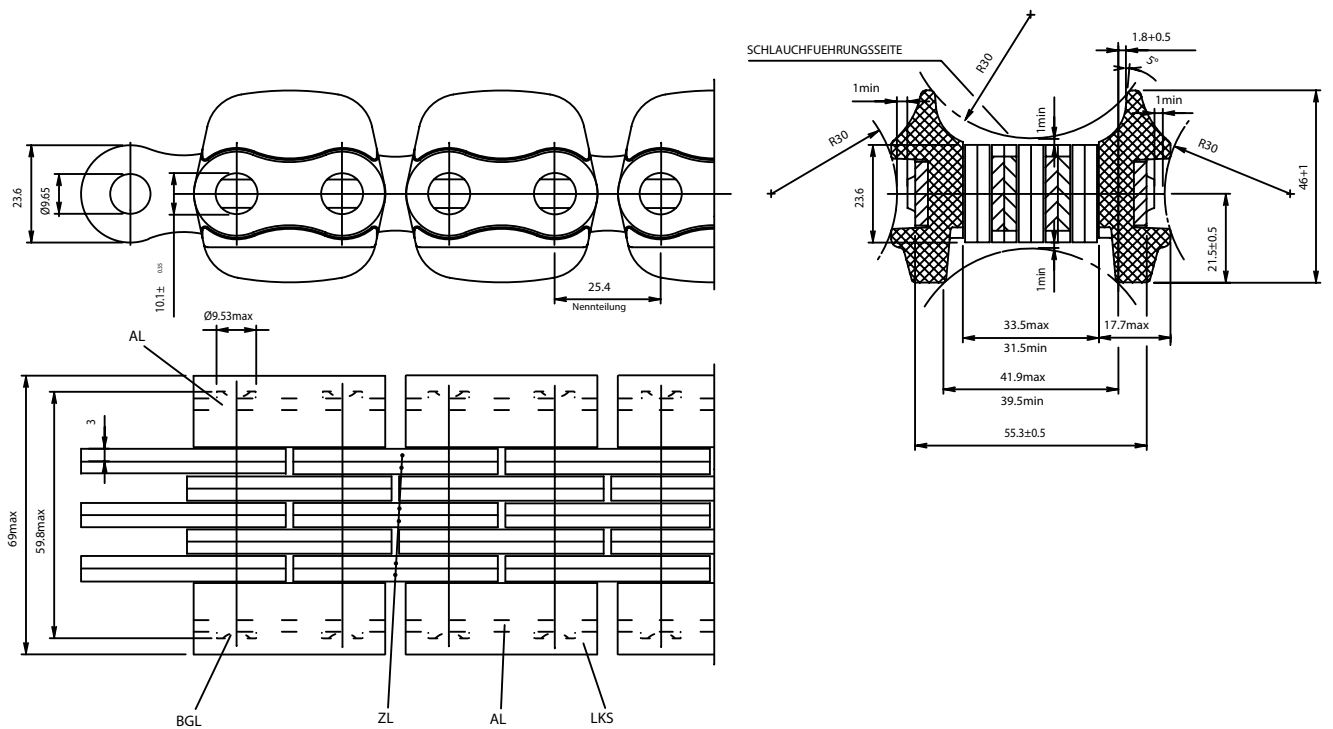

BL 866 KS

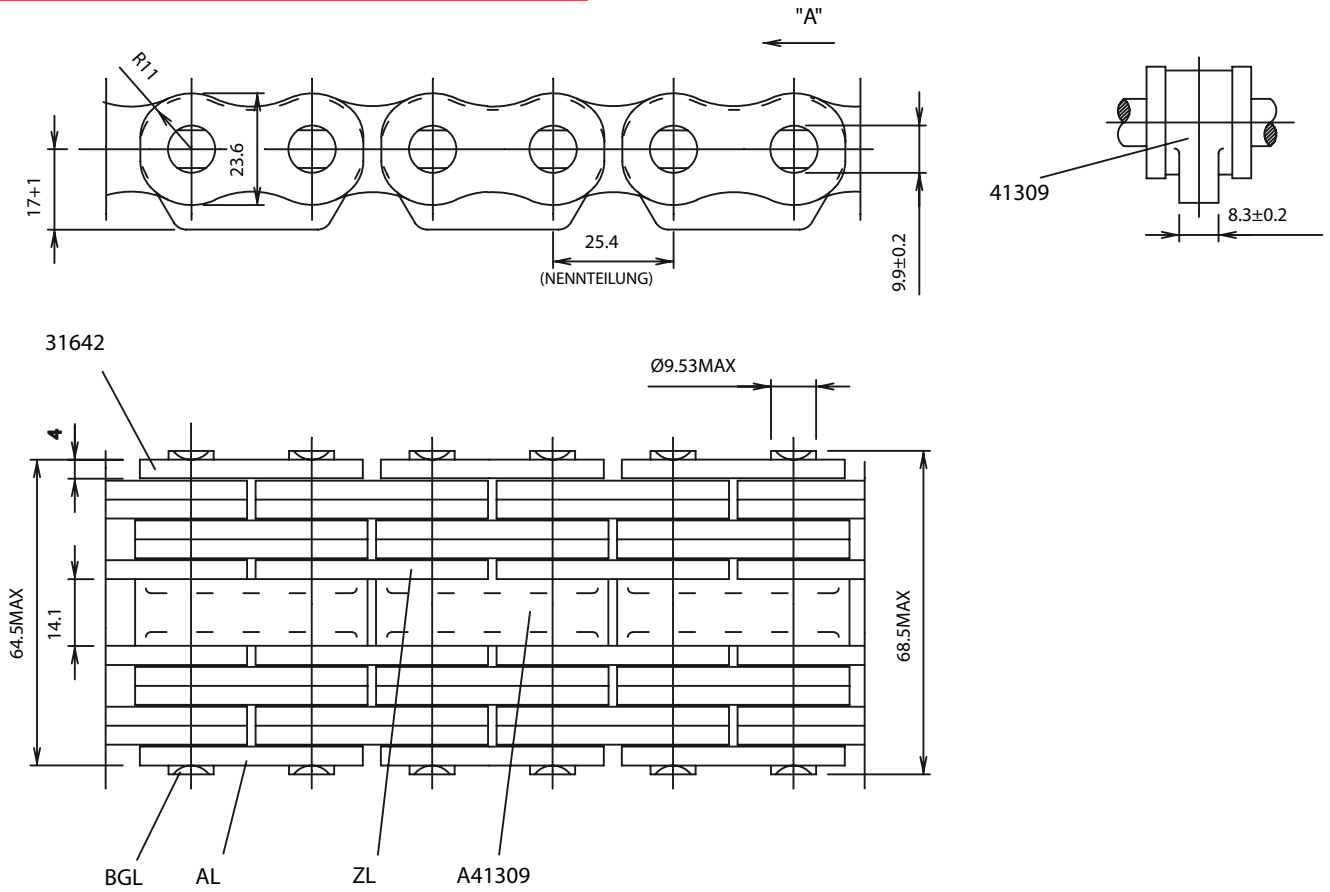

BL 888 KS

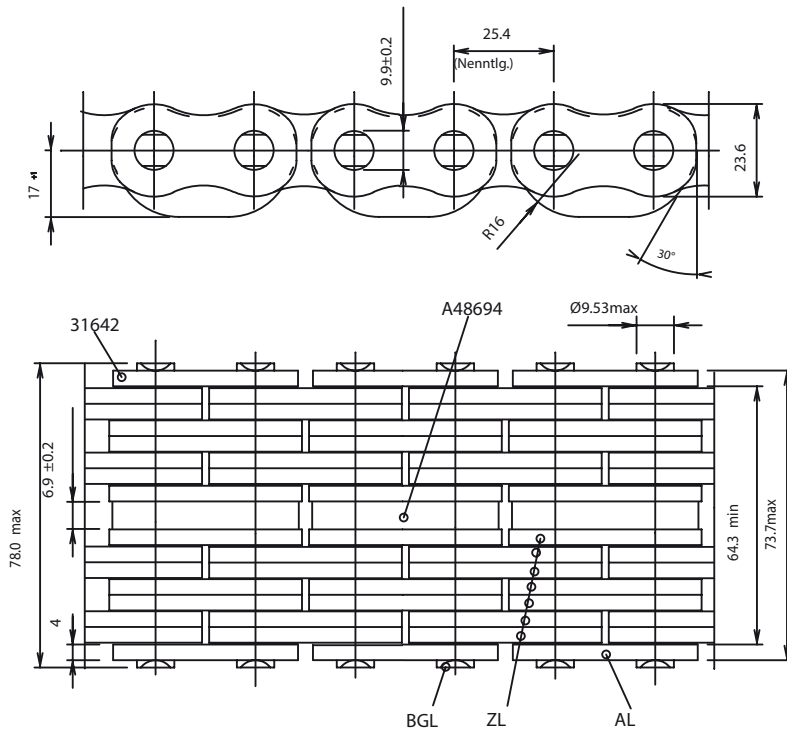

F 31 V-88 KS

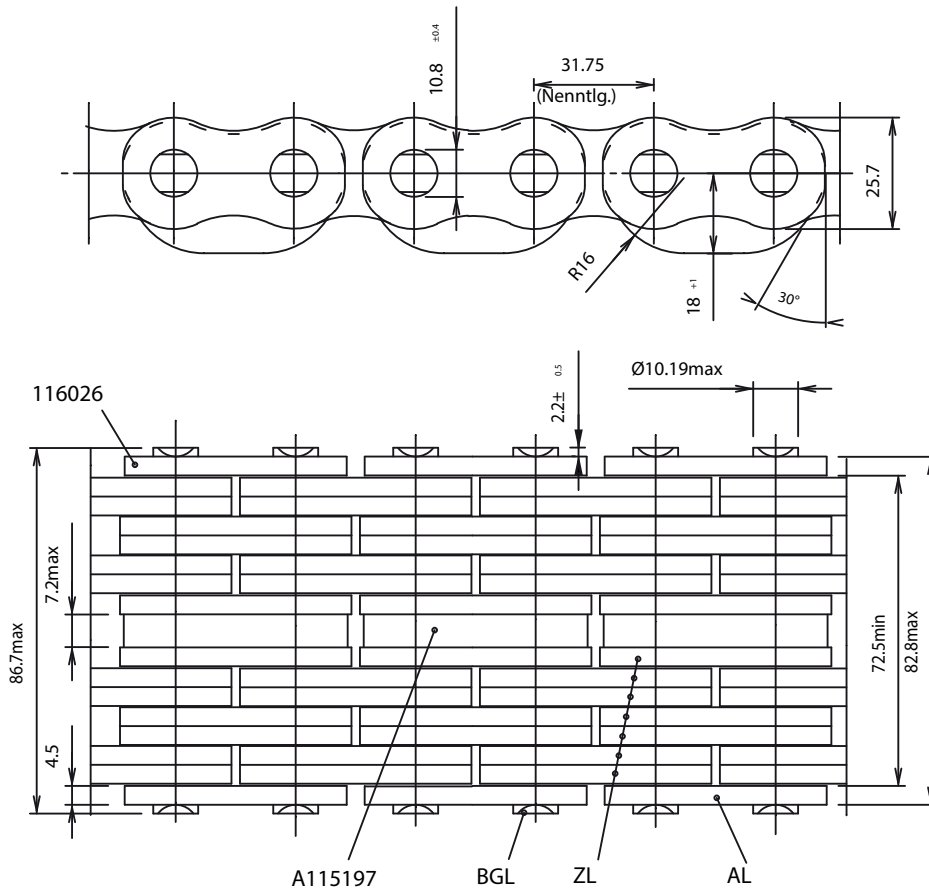

BL 1446 I HP

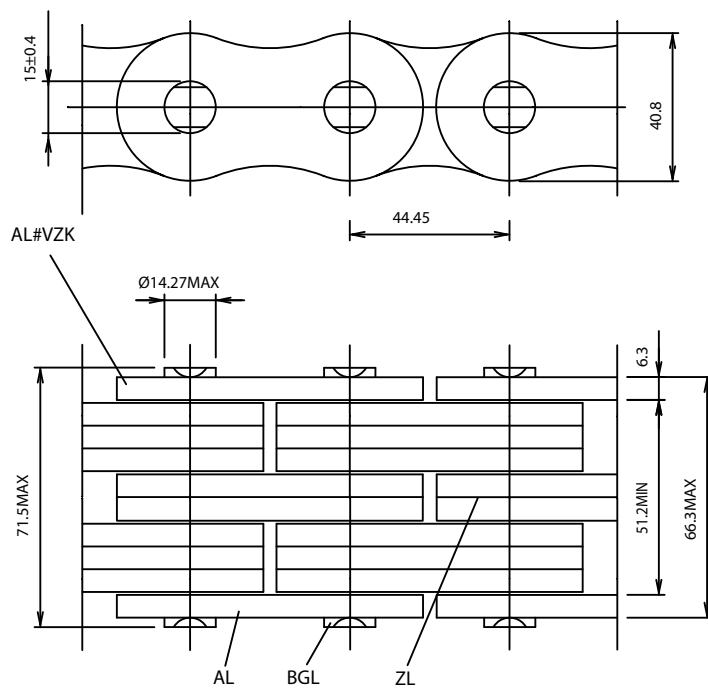

BL 1644 I HP

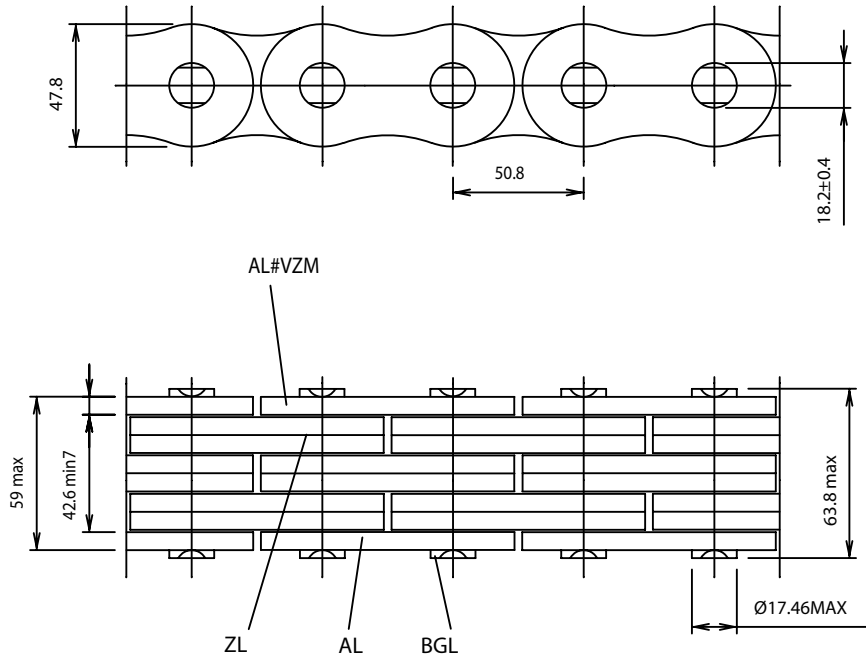

BL 1666 I HP

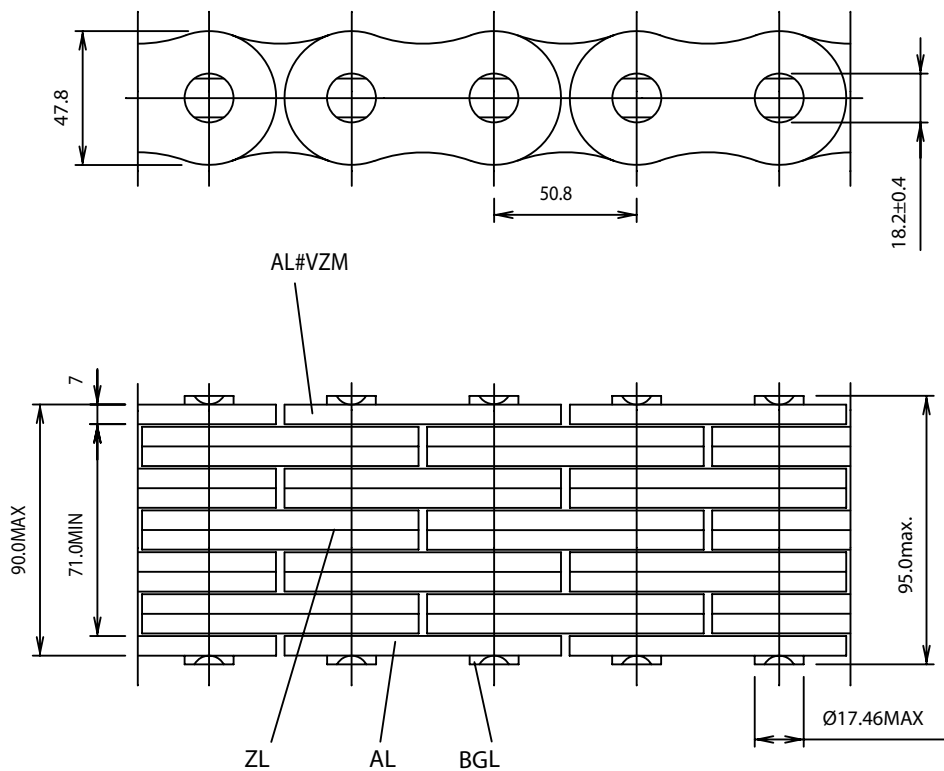

F 25-44 KS

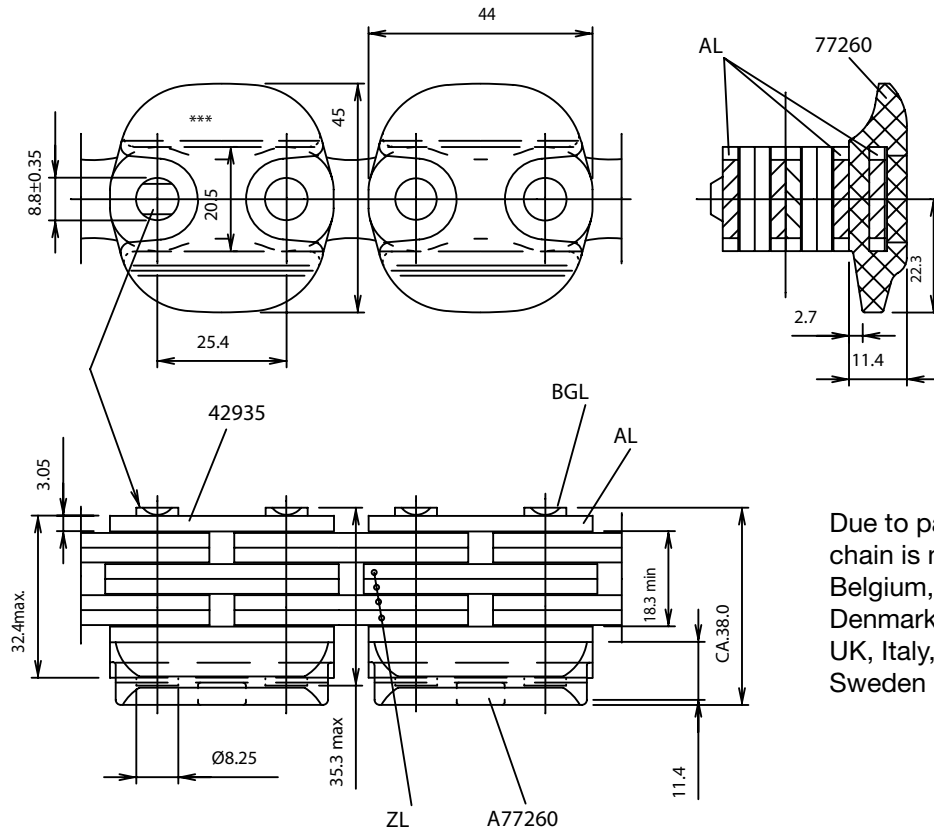

Due to patent reasons this chain is not available in Belgium, Germany, Denmark, Spain, France, UK, Italy, Netherlands und Sweden

FS 25-66 KS

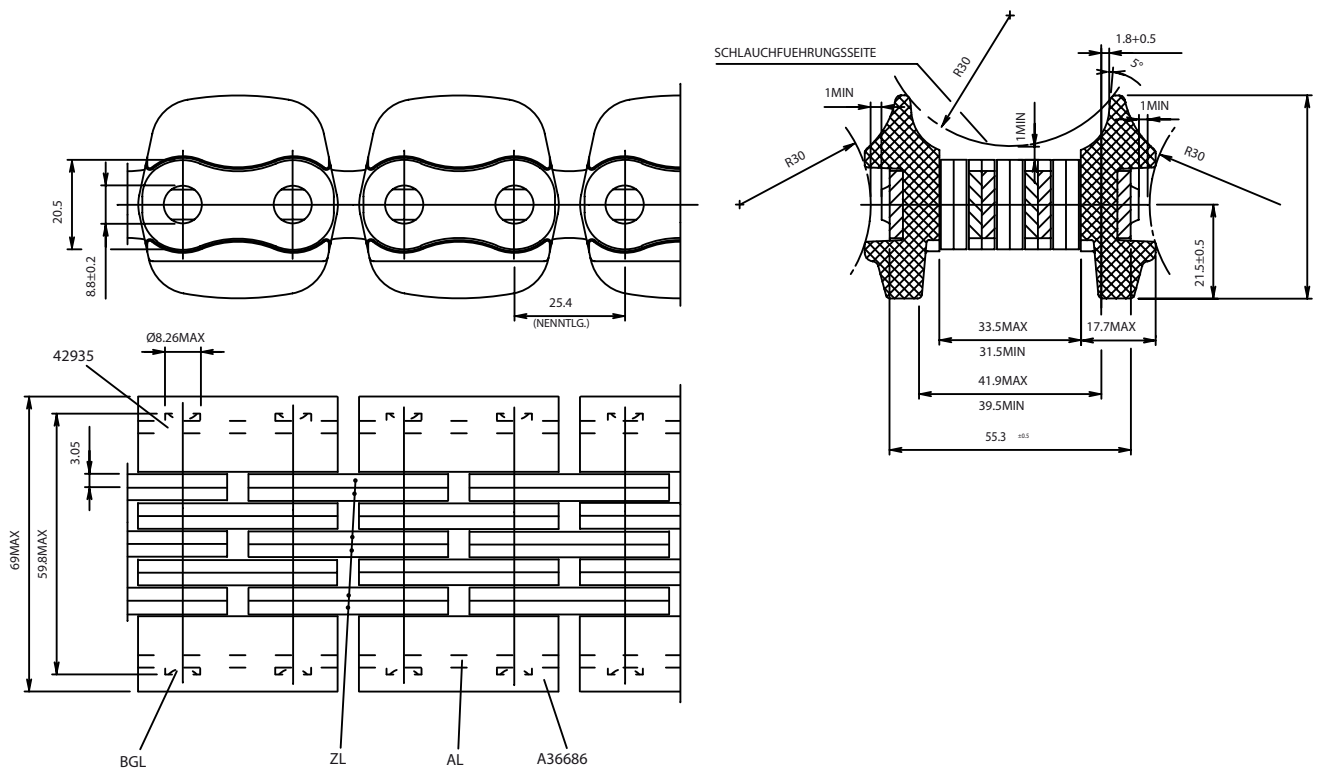

FS 44 H-66 KS

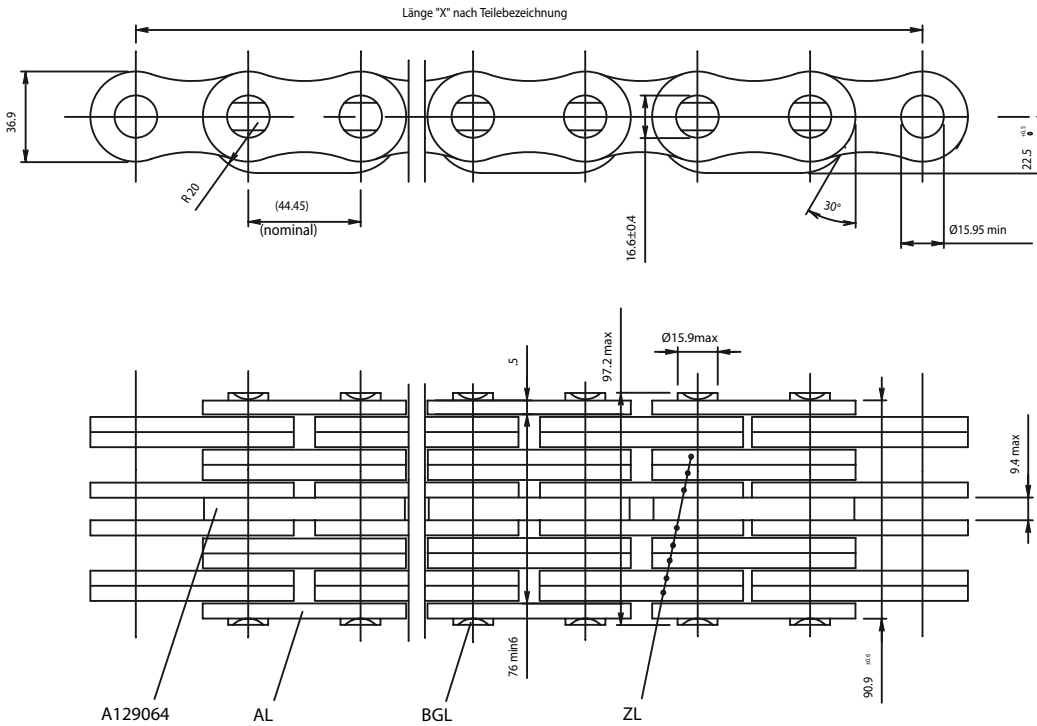

Rexnord sets new standards - every day

Rexnord chains are used in all types of situations where the highest demands must be met. With a product range of over 8000 variations of quality chains in standard and special categories, Rexnord offers a formidable selection of chains for almost all industrial applications.

To keep Rexnord chains functioning properly as long as possible and to increase their service life, a certain amount of maintenance and lubrication of the chains is required. REXOIL fulfills all criteria demanded for an effective chain lubricant.

The correct chain lubricant

Lubrication intervals are dependant upon the chain use and the operating environment of the chain. For optimum performance, there must be a sufficient amount of oil inside the chain links at all times. Chains are correctly lubricated and in best condition when:

1. No new dirt adheres to the chain
2. Chain is wet to the touch. These characteristics show that the chain link has adequate lubrication.

Avoiding malfunctioning

About 60% of all chain malfunctions in chains can be traced back to the wrong lubrication. If the applied lubricating agent only stays on the surface without penetrating into the chain joint, then there is insufficient lubrication, which will cause the chain to deteriorate with damaging consequences - i.e. premature wear. This will occur when the lubricant does not have the right viscosity. Very often, the lubricant being used has a basic viscosity which is too high and must be thinned with another agent so that it remains fluid. Once applied to the chain, the thinner evaporates and leaves thick grease on the chain surface. The result is that no lubricant reaches the chain links. Dirt attaches itself to the new grease and builds up on the surface of the chain. Consequently the links become corroded and stiff, pitting of the chain occurs, and the noise level is increased.

It all depends on the lubrication

The high performance lubricating oil for chains is REXOIL, which possesses outstanding lubricating characteristics, as well as high resistance to oxidation. REXOIL also has the ability to penetrate and disperse water, while protecting the chain from corrosion and loosening hardened grease. A chain can be lubricated easily and fast due to the extended spray nozzle - even the application has limited access.

REXOIL advantages at a glance

REXOIL will do what it should:

- has outstanding lubricating characteristics
- provides effective corrosion protection and high resistance to oxidation
- easy and safe to handle due to extended spray nozzle
- loosens old hardened grease
- is able to penetrate and disperse water
- proven to be the solution for fork-lift trucks, conveyors, packaging machines, and machines in the textile industry, robots, etc.
- can be applied in temperatures between -10°C and +150°C (+14°F and +302°F)
- is free from FCKW and CPC
- is licensed according to NSF H2 regulations

By using REXOIL, chain lubrication becomes extremely simple dependable, economical and environmentally friendly.

If you have any questions regarding chain lubrication, please contact Rexnord's application engineers: Fon +49 2741 284 0

Lubrication and maintenance instructions

For Rexnord Leaf Chains.

1. Lubrication

1.1. Ex- Work lubricant of the chain

The chain is lubricated "Ex Work" with RexPro (VSK 001). The lubrication is for original lubrication and corrosion preventive.

1.2 Re- Lubrication

Adequate Lubrication can extend the lifetime of a chain many times. The amount of lubricant is not important, but it must find it's way into the chain joints. The graphic (fig. 1) shows a chain link and demonstrates that the lubricant has to pass a narrow gap between the sideplates in order to enter the chain joint which consists of pin and inner plates.

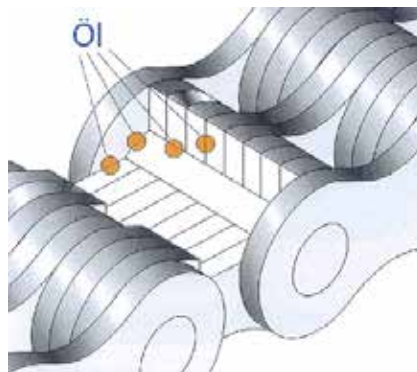

figure 1: cross section of a chain joint

The chain has to be re-lubricated short after start of service. A re-lubrication during the initiation is not required, if the ex-works lubricant is a non- standard lubricant with special properties.

1.2.1 Lubrication Products

Mineral oil ISO VG 68 to 220 at temperature of using (for instance Rexoil, motor oil or gear oil) can be used for leaf chains. The viscosity of the oil depends on the environmental temperature and on the types of lubrication.

Environmental Temperature	Class of Viscosity	Recommended Products*
> - 40°C < - 30°C	VG 15	Klüberoil 4UH 1-15 – Klüber Lubrication
> - 30°C < + 5°C	VG 68	Klüberoil 4UH 1-68N – Klüber Lubrication Anticorit LBO 160 TT – Fuchs DEA
> + 5°C < + 45°C	VG 150	Klüberoil 4UH 1-150N – Klüber Lubrication Anticorit LBO 160 – Fuchs DEA Rexoil – Rexnord Kette
> + 45°C < + 80°C	VG 220	Klüberoil 4UH 1-220N – Klüber Lubrication Rexoil – Rexnord Kette

Indication: Do not use thickening grease or thickening lubricants. Oil containing graphite or molybdenum disulphide should not to be used. The reason is: grease collar.

1.2.2 Lubrication Method

The type of lubrication depends on the environmental conditions. Manual lubrication can be applied by brush, oil can or spray for chain drives with a speed up to 0,5 m/s. Between 0,5m/s and 2m/s you can use the drip lubrication. With a dosing device sufficient oil has to be applied on the high plate cross- section, so that it can penetrate into the bearing areas of the chain.

1.2.3 Intervals of Lubrication

The first lubrication of the chain has to be made when the chain is put into service. Further lubrication intervals have to be applied according to usage. The general recommendation is to re-lubricate the chains every 500 hours.

The quantity of lubricant and the intervals of lubrication have to be chosen in order to keep always enough free- flowing oil in the joints.

Furthermore, a thin oil film has to cover the surface of the chain to prevent the chain from corrosion.

1.2.4 Storage

New Rexnord Chains can be stored in their packing. If the time of storage is longer than 12 months, the chain should be extra covered with a protection oil.

Unprotected, lubricated oil get contaminated with dirt and other material, can damage the chain and other components.

2 Cleaning

If, for any reason the chain becomes contaminated during use so that the penetration of the lubricant oil is no longer guaranteed, it will become necessary to clean the chain. The cleaning can only be made by paraffin derivatives like diesel oil, motor oil, petroleum, cleaning gasoline, etc.

Cleaning by steam jet, the use of cold cleaners or even caustic and acidic products must not be undertaken. These products can damage the chain by hydrogen embrittlement.

3 Inspection

3.1 Plan for Inspection

Regular Chain inspections are the base for achieving the maximum possible service life for the chain.

The following inspection plan should be followed:

every three months

- Control and adjust of chain set- up.

yearly

- Carry out the above mentioned inspection.
- Check the wear of links.
- Measure the chain length.
- Control the cleanness of the components.
- Remove of dirt and accumulation.
- Check rivet and adjustment of deflection roller.
- Check deflection roller wear.
- Check lubrication:
 - Line not clogged?
 - Amount of drips is adequate (Drop lubrication).
 - Oil- level is according to the specification (Drop lubrication).

Important

The chain has to be inspected immediately, if:

Elongation is over 2%.

There are visible wear marks on the plates and / or corrosion.

A mistake in the lubrication system did occur.

A system failure did occur and therefore the chain had a load peak to suffer.

By heavy dirt and hyper humidity.

3.2 Criteria of Control

3.2.1 Elongation due to wear

The examination of a long and stretched piece of chain is required to measure the elongation of wear. The measurement should be made from one middle of the pin to the other middle of the pin.

The number of pitches in the measuring range, multiplied by the chain division gives the nominal size. The length exceeding this nominal size represents the wear.

The permissible elongation due to wear for leaf chains is 3%. With the help of the Rexnord wear ruler the wear elongation can be determined. It is for the pitch size from $\frac{1}{2}$ " up to $2 \frac{1}{2}$ ".

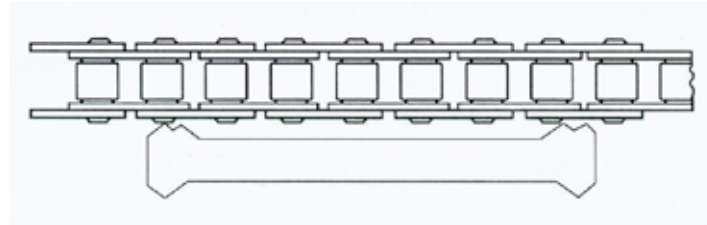

figure 2: Rexnord wear ruler

3.2.2 Tension of the chain

During the inspection the tension of the chain has to be examined and adjusted.

3.2.3 Surface rust

Surface rust can be easily recognised by the brown colour appearing on the plates. The pitting formations (small craters appearing on the surface), result from the corrosion, can be the starting point of fatigue fractures.

If rust on the surface of the chain is determined, you have to increase the lubricant film.

3.2.4 Twisted pins

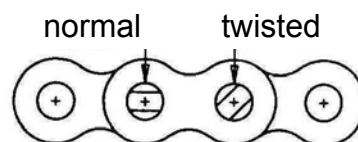

figure 3: turned pins

Does the chain has twisted pins then the blocking of the links is so strong that the press fit between the pins and the outer plates have been overcome.

Chains with twisted pins are no more reliable and have to be replaced.

3.2.5 Stiff links

The chain joint is no more functional if the chain links do not return at the stretched position after abandoning the sprocket. This phenomenon can be due to cold welding, friction corrosion, or strong dirty.

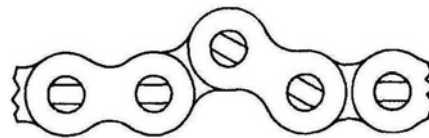

figure 4: stiff links

If the stiff chain joints do not operate after being cleaned and lubricated, the chain has to be replaced.

3.2.6 External wear

Inspections must be made to determine whether the plates of the chain indicate signs of inadmissible external wear. The wear must not exceed 5% of the primary plate cross-section.

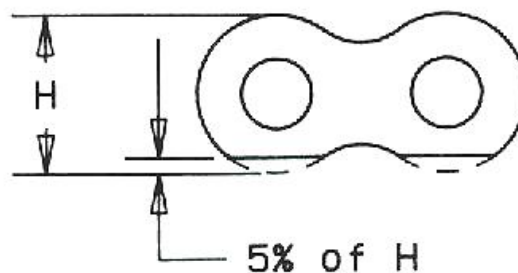

figure 5: plate with external wear

3.2.7 Damages

Do the chain plates show marks of impact or other deformations? Is wear in the holes visible?

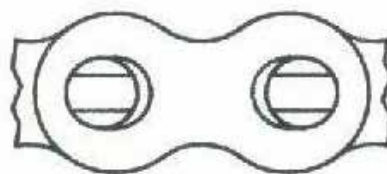

figure 6: wear at plate bore

3.2.8 Broken plates

Broken chain plates can be recognized by an "opening" of the plate in the area of the plate head or by an absence of this head part. This is a fatigue fracture (repeated stress failure) due to an overload.

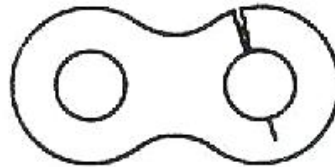

figure 7: broken plate

Corrosion can be a cause of fracture breakage too.

4 Test run

It is advisable to do a test run with the chain to regulate the oil feed, remove oil drips and check if unusual noise and vibrations arise. After the test run the chain has to be examined carefully.

For more information and support do not hesitate to contact

Rexnord Kette GmbH
Tel.: +49(0)2741/284-0
Fax: +49(0)2741/284-253
email: rexinfo@rexnord.com
web: www.rexnord.de

REXNORD Kette GmbH
i. A.

Thomas Gontermann / 01 June 2012
Product Technology and Application



Zentrale
Rexnord Kette GmbH

Industriestraße 1
57518 Betzdorf / Germany

Fon: +49 2741 / 284 - 0
Fax: +49 2741 / 284 - 250

E-mail: rexinfo@rexnord.com
www.rexnord-kette.de

Headquarter
United States, Milwaukee
Rexnord Industries, Inc.

4701 W. Greenfield Avenue
Milwaukee, WI 53214

Fon: +1-414-643-3000
Fax: +1-414-643-3078

www.rexnord.com